

ASKotec Tutorials - DIY Simple analog synth

One of the simplest analog synths inspired by LOOK MUM NO COMPUTER

<https://www.youtube.com/channel/UCafxR2HWJRMfSdyZXvZMTw>

 Difficulté Facile

 Durée 1 heure(s)

 Catégories Art, Électronique, Musique & Sons

 Coût 10 EUR (€)

Sommaire

Introduction

Video d'introduction

Étape 1 - Mark Prototype Board

Étape 2 - Solder Basic Components To Board

Étape 3 - Bridge Potentiometer Channels

Étape 4 - Wire 1

Étape 5 - Wire 2

Étape 6 - Wire 3

Étape 7 - Wire 4

Étape 8 - Wire 5

Étape 9 - Solder component legs

Étape 10 - Solder DC Connector

Étape 11 - Create Safety Strap

Étape 12 - Prepare moveable elements

Commentaires

Introduction

This simple diy analog synth is part of an upcoming series of little projects, that can be used to learn about basic electronics, while having fun with the result.

As the synth has a chip socket, you will be able to change the pitch range of the sound through different capacitors. Just change it on the fly, or keep it and build several of these synths.

You can use sound effect software like <http://rakarrack.sourceforge.net/>. Check out the video!

There will be build-up tutorials in the future. Have fun!

<https://openculture.agency/outcomes/askotec/>

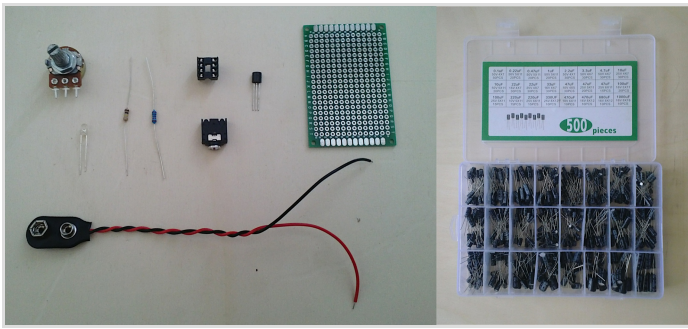

Matériaux

- 1k Resistor
- 100k Resistor
- Transistor SS9018HBU TO-92
- 10k Potentiometer
- LED Diode
- Capacitors (smaller value higher pitch)
- Wires (2 Colors)
- Prototype Board
- Battery Connector (and 9V Battery)
- Mini Jack Audio Socket
- 8 Pin RoHS PCB IC Socket

Outils

- Soldering iron
- Soldering wire
- Soldering grease
- Marker
- Sucker
- Pliers

Étape 1 - Mark Prototype Board

1. Take your time and look at the schematic. Start with + and run through the different ways till you end back to - pole
2. The second image shows you the pins you are going to use
3. Go and mark all pins on your board

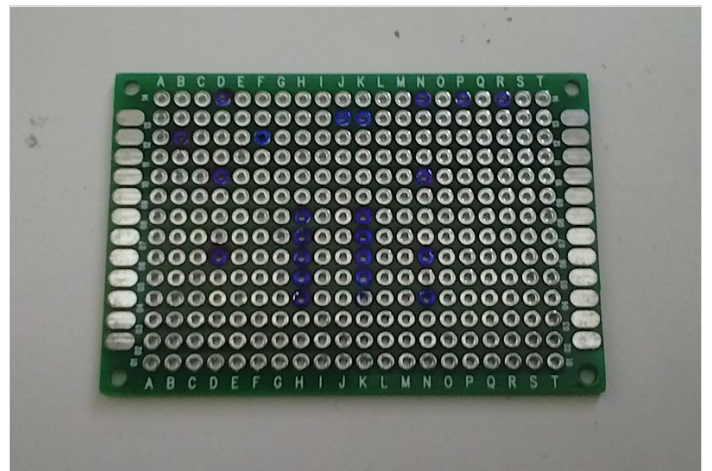
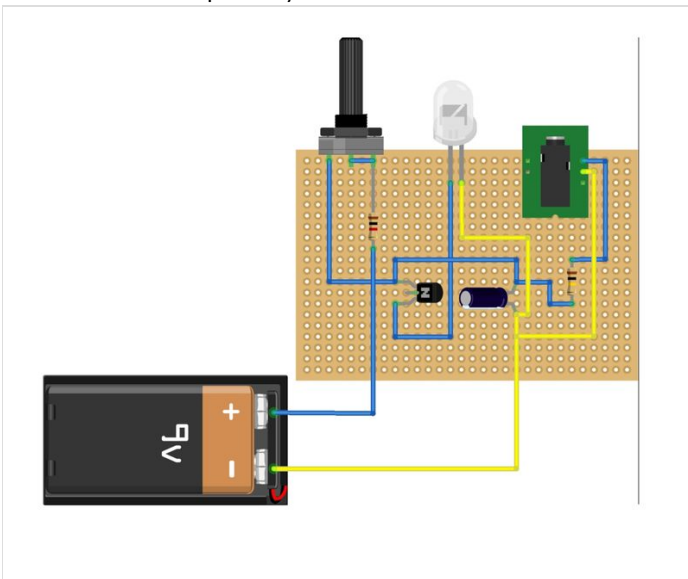

Étape 2 - Solder Basic Components To Board

1. Take each basic component and put it onto the marked place (You might need to use some tape to hold the elements in place)
2. Check, if + of LED is on the shown side
3. Solder each part on the board...DO NOT CUT THE LEGS, WE NEED IT!!!
4. Bend the legs like it is shown in the second image

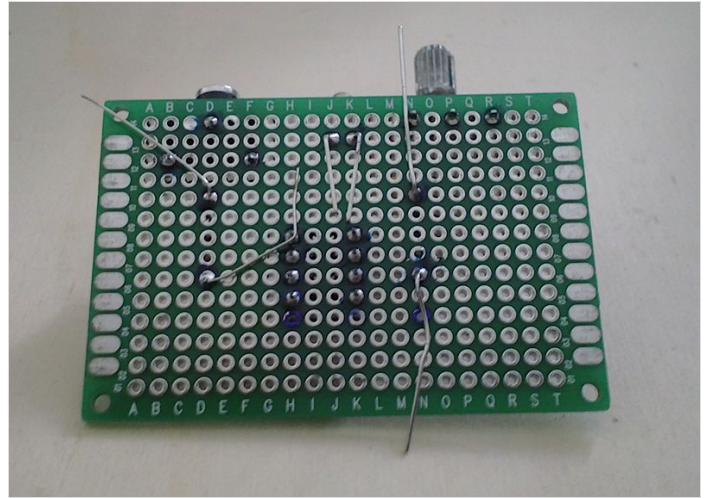
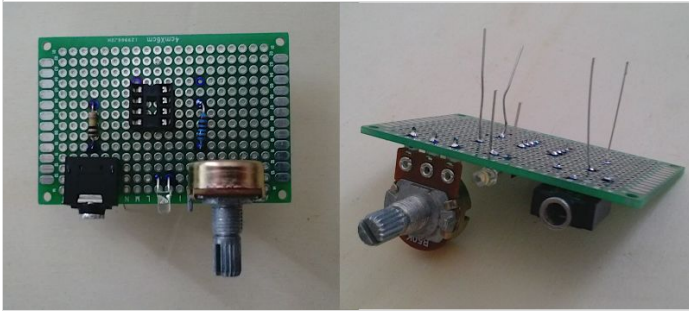

Étape 3 - Bridge Potentiometer Channels

1. Cut the overlapping part of the leg shown in the picture
2. Bend the piece like an wide U, and put it into the place at the potentiometer
3. Solder the U to bridge the channels

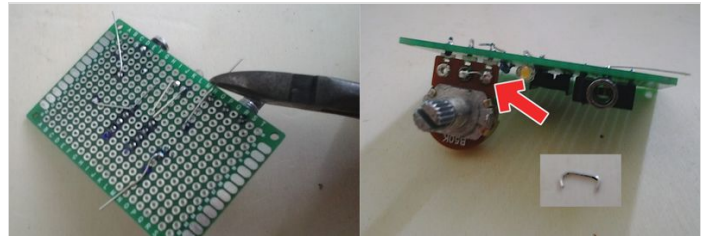

Étape 4 - Wire 1

- Solder the wire as shown
- Using this prototype board, you will need to connect wires to the soldered elements directly
- Compare the schematic with the photos to see which pins need to be connected
- Be careful not to bridge other pins accidentally

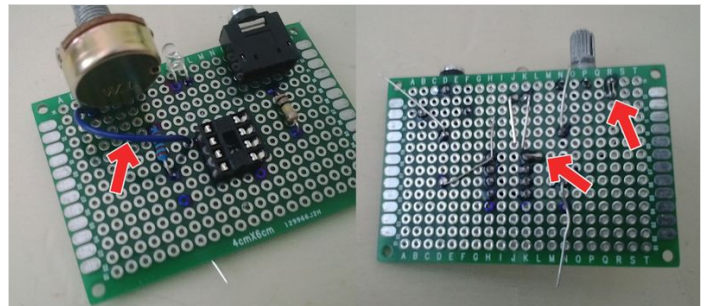

Étape 5 - Wire 2

- Solder the wire as shown
- Using this prototype board, you will need to connect wires to the soldered elements directly
- Compare the schematic with the photos to see which pins need to be connected
- Be careful not to bridge other pins accidentally

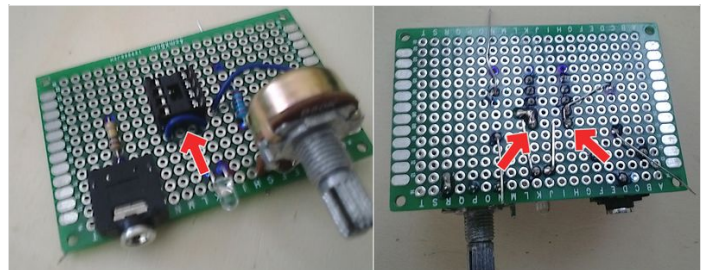

Étape 6 - Wire 3

- Solder the wire as shown
- Using this prototype board, you will need to connect wires to the soldered elements directly
- Compare the schematic with the photos to see which pins need to be connected
- Be careful not to bridge other pins accidentally

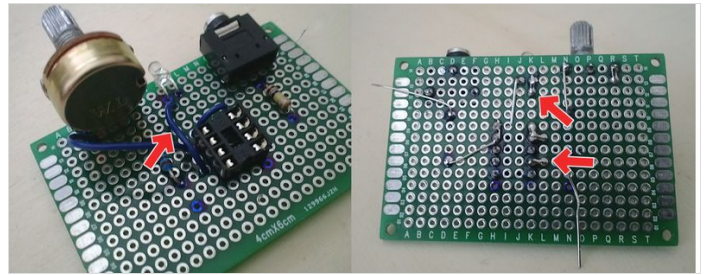

Étape 7 - Wire 4

- Solder the wire as shown
- Using this prototype board, you will need to connect wires to the soldered elements directly
- Compare the schematic with the photos to see which pins need to be connected
- Be careful not to bridge other pins accidentally

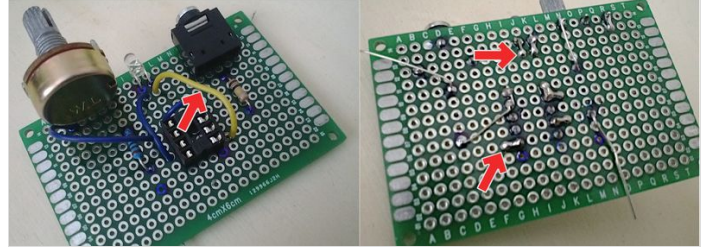

Étape 8 - Wire 5

Here you need to take of a bigger piece of the wires isolation, so you can then use it to get to the jack sockets ground pin on the other side. Check the second image

- Solder the wire as shown
- Using this prototype board, you will need to connect wires to the soldered elements directly
- Compare the schematic with the photos to see which pins need to be connected
- Be careful not to bridge other pins accidentally

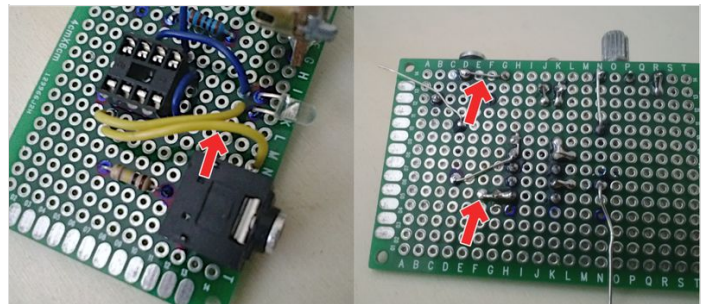

Étape 9 - Solder component legs

Now use the legs of the basic soldered components, and connect it like shown in the image

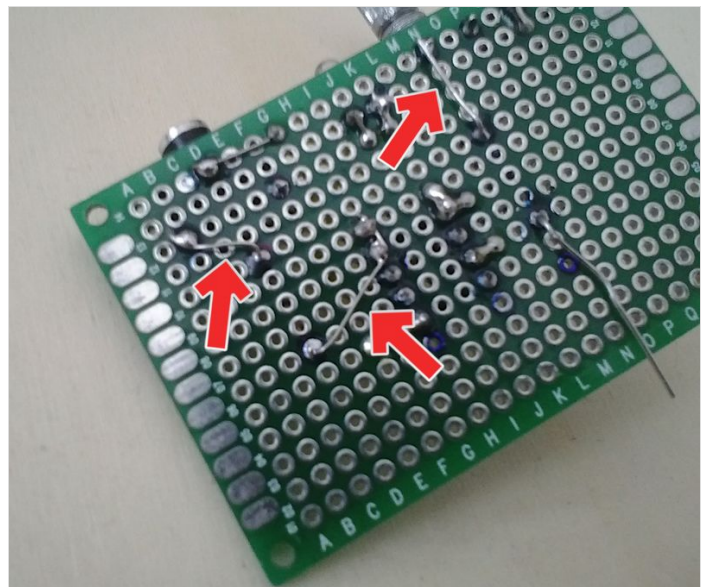

Étape 10 - Solder DC Connector

- Solder the wire as shown
- Using this prototype board, you will need to connect wires to the soldered elements directly
- Compare the schematic with the photos to see which pins need to be connected
- Be careful not to bridge other pins accidentally

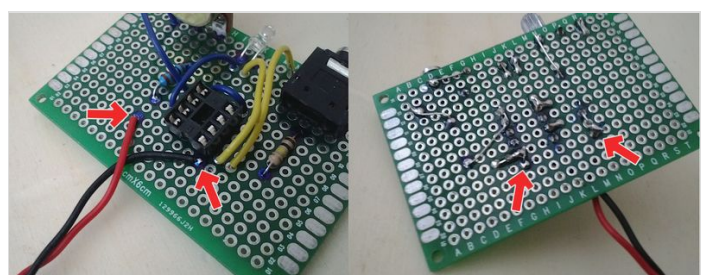

Étape 11 - Create Safety Strap

- Solder the wire as shown
- Using this prototype board, you will need to connect wires to the soldered elements directly
- Compare the schematic with the photos to see which pins need to be connected
- Be careful not to bridge other pins accidentally

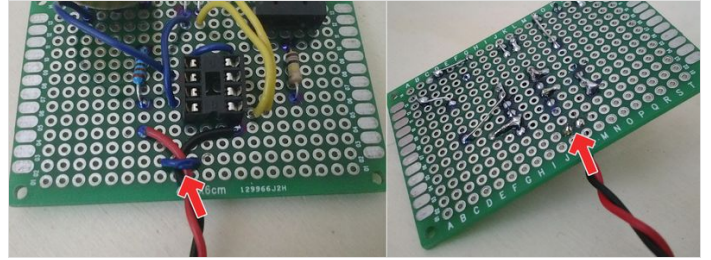

Étape 12 - Prepare moveable elements

1. Cut off the middle leg of the Transistor SS9018HBU TO-92, and plug it into the socket left 1st and 3rd
2. Plug in the first capacitor into the socket right, with + in the 1st and - in the 4th
3. Plug in an audio cable to an amplified speaker, or laptop
4. Connect the battery

FINISHED! OFF YOU GO, AND HAVE FUN WITH YOUR LITTLE SYNTH!!!

Remember. If you change the capacitor size, you will have different pitch ranges.

