

**Wakatlab Autonomous
irrigation system with
controlled watering zone
training manual.**

Table of contents

I. Introduction

ii. Training tools and materials

iii. Lists of training materials

iv. Design process

Introduction

This is a self-guide which any young technical professional can use to learn how to make an automated irrigation system

The drip irrigation system is a localized micro-irrigation technique commonly used in Burkina Faso. It allows precise control of water supplies at root level and at low flow, thus reducing losses. Our System aims to improve the drip irrigation system and allows different watering of various crops in a field depending on the moisture content of the soil.

Lists of training materials

- ArduinoNano microcontroller
- Water pumps
- Soil moisture sensors
- Solenoid valves
- Potentiometers
- Connectors
- Solar panel

Design Process

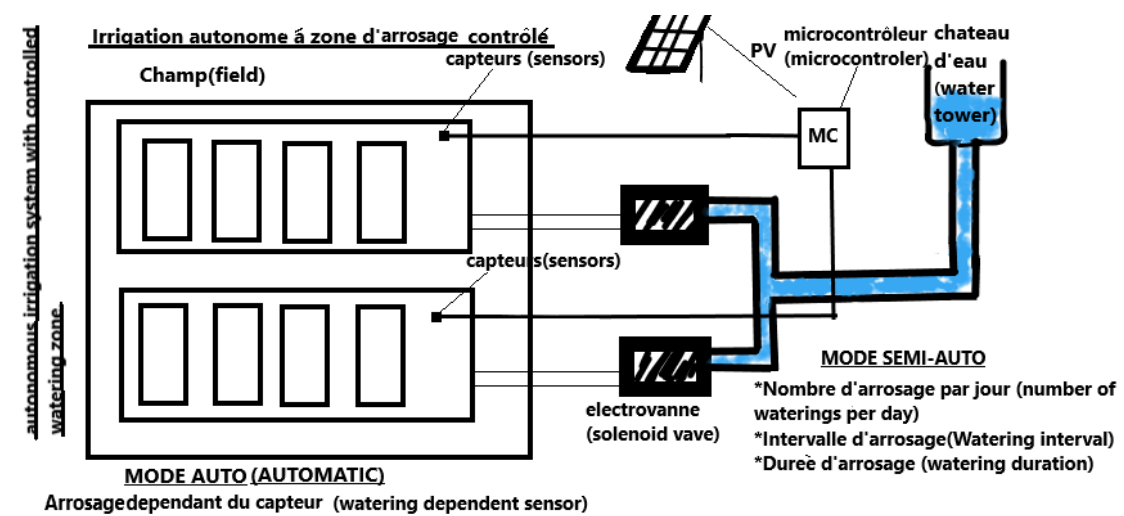

Step 1

- Get a sand box and separate the sandbox into two compartments corresponding to culture A and culture B.

Step 2

- In each compartment has been installed a plastic pipe. To install this pipe we drilled two holes in the cardboard. At the level of each plant was installed a dripper connected to the pipe.
- At the other end of the pipe is the motor which will pump the water. The motor can be replaced by a solenoid valve, but the latter requires more pressure in the pipe. The pump is submerged in a water tank. So that the pump can work, a micro controller will give the order to the pump according to the message that the sensors will give as information.

Step 3 (electrical connection)

- Their sensors are embedded in the sand. They send the information of soil temperature and humidity to the micro controller. This micro controller depending on the state of humidity operates the pumps mentioned above.
 - The micro controller program is as follows: To power everything we used we used a 220V power supply which can be replaced by a solar panel. Two converters were used to supply the electronic circuit: One converter takes 220 V to send 12 V output. The second converter takes 12 V to send 5 V output which is then used to supply the electronic circuit which does not use than 5 V.