

Tabouret CastoLab

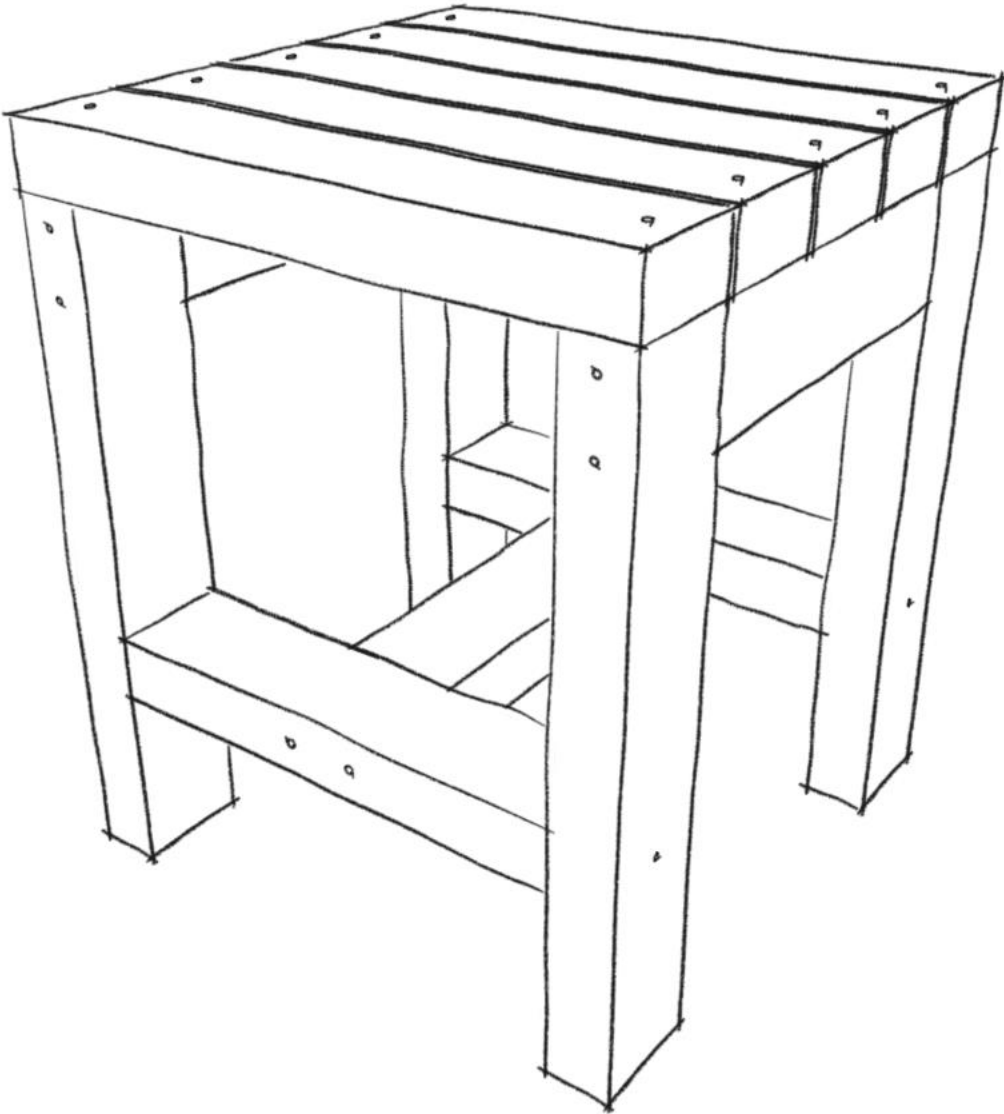

# Tabouret CastoLab

La fabrication du tabouret nécessite:

- 2 Tasseaux en sapin raboté 38 x 67 mm L.2,4 m (ref 628678)
- 14 vis longueur 60 mm (ref Casto 124238)
- 12 vis longueur 5 x 100 mm (ref Casto 633846)
- Colle bois

**Cout approximatif des composants: 35 €**

REF	L x l x h (mm)	Qtés
A	392 X 67 X 38	4
B	355 X 67 X 38	5
C	279 X 67 X 38	2
D	221 X 67 X 38	3

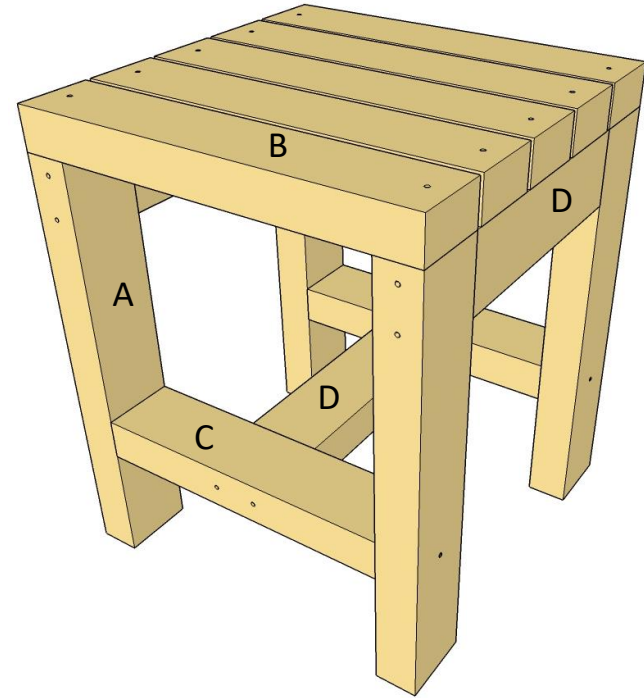

Plan de découpes des tasseaux



# Tabouret CastoLab

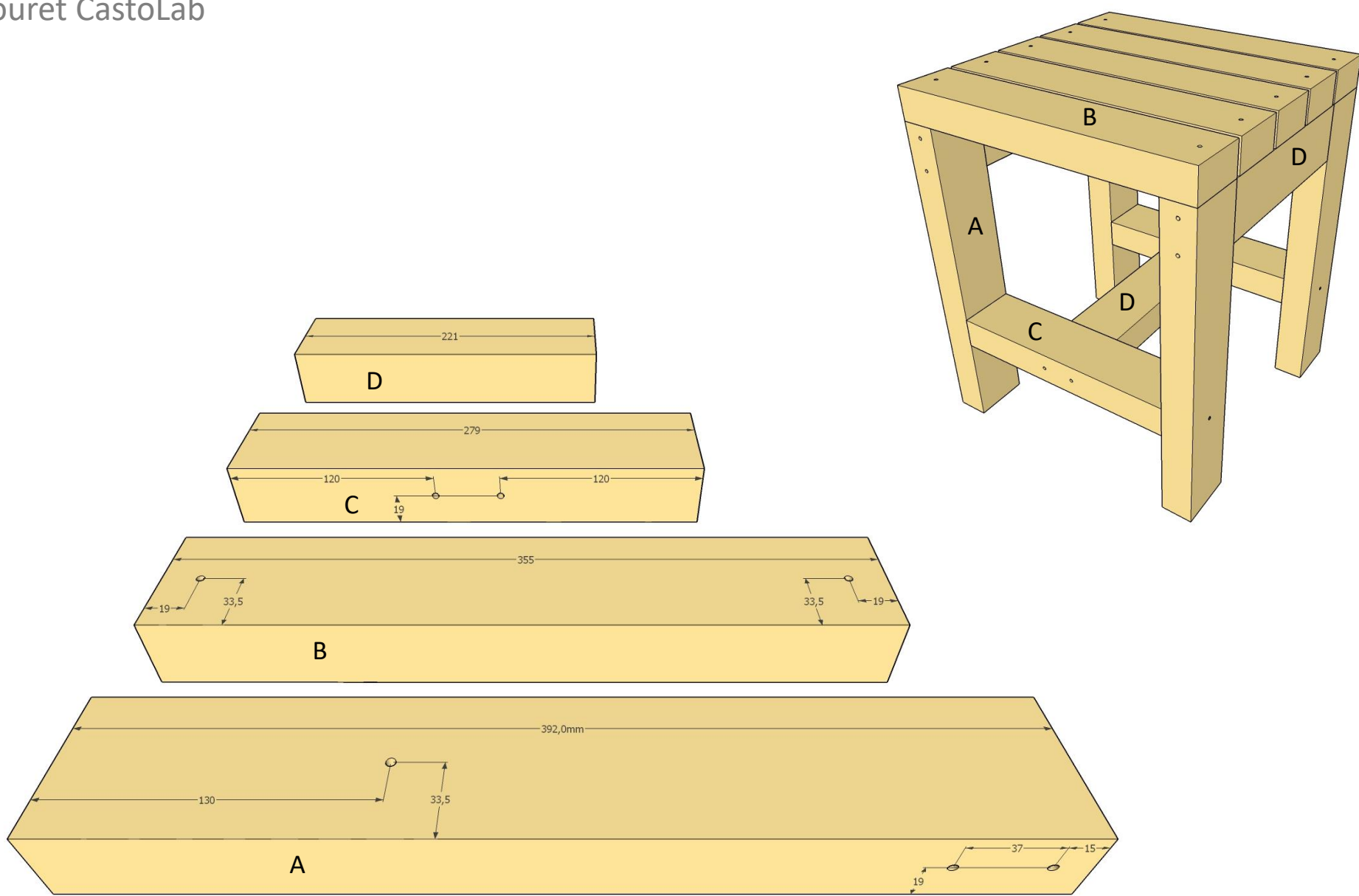

Tabouret haut CastoLab

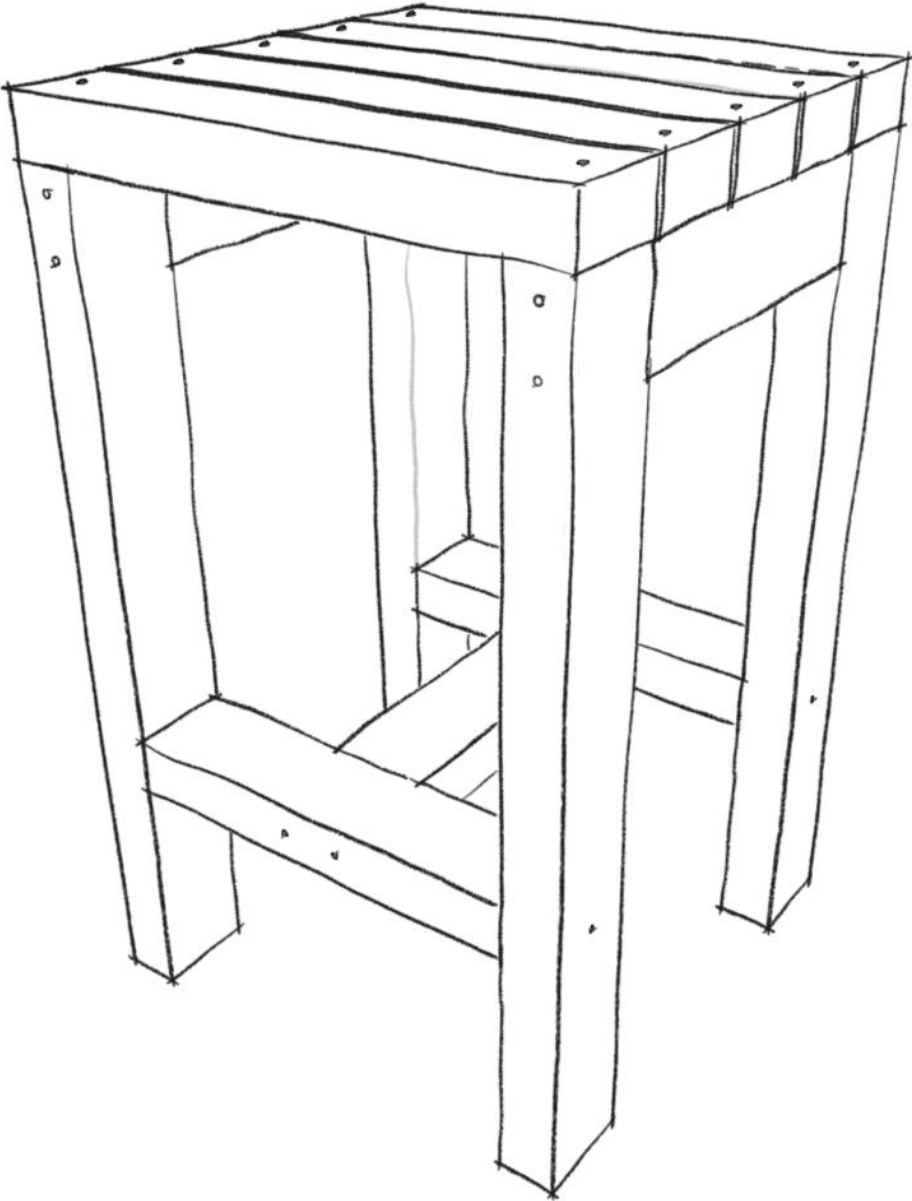

# Tabouret haut CastoLab

La fabrication du tabouret nécessite:

- 3 Tasseaux en sapin raboté 38 x 67 mm L.2,4 m (ref 628678)
- 14 vis longueur 60 mm (ref Casto 124238)
- 12 vis longueur 5 x 100 mm (ref Casto 633846)
- Colle bois

**Cout approximatif des composants: 45 €**

REF	L x l x h (mm)	Qtés
A	562 X 67 X 38	4
B	355 X 67 X 38	5
C	279 X 67 X 38	2
D	221 X 67 X 38	3

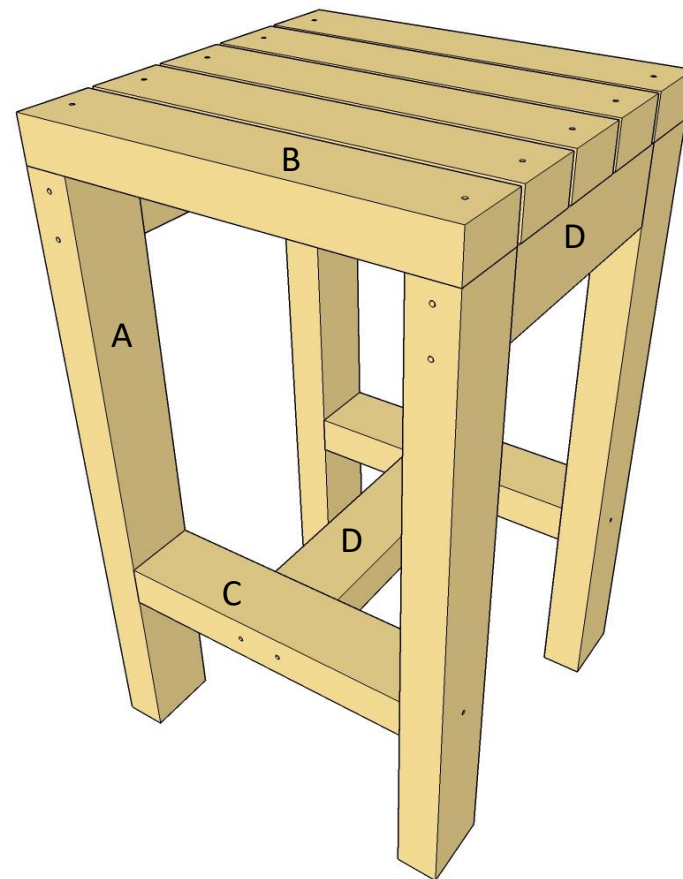

Plan de découpes des tasseaux

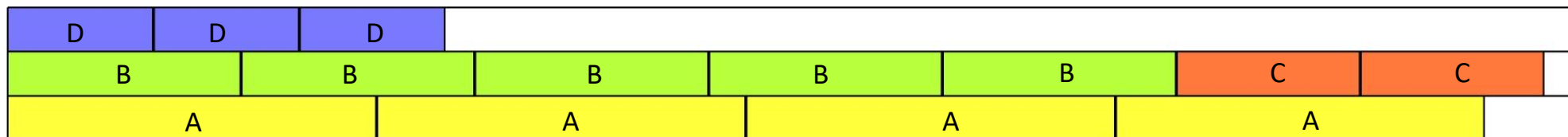

# Tabouret haut CastoLab

